

ATAK SERİSİ / ATAK SERIES

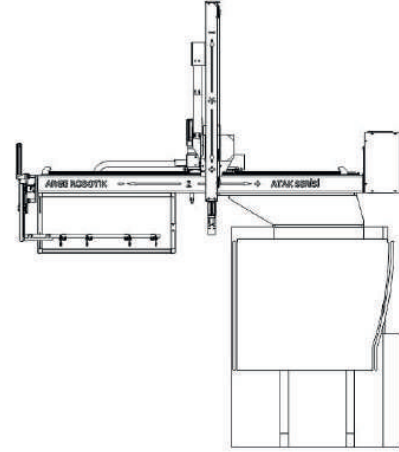
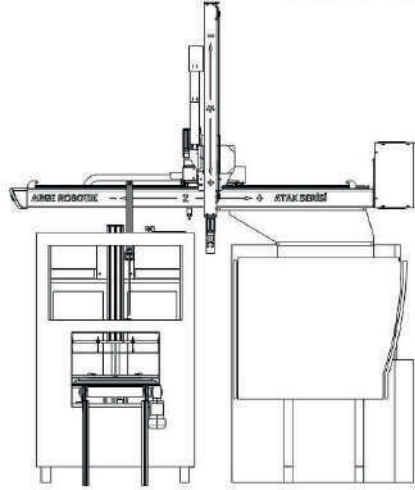

A TİPİ UYGULAMA / APPLICATION TYPE A

Etiketlenmiş ürünler kalıp içerisinde alınarak konveyör üzerine dizilir.

Labeled products are taken from the mold and stacked on the conveyor.

B TİPİ UYGULAMA / APPLICATION TYPE B

Ürünler kalıp arasından aşağıya bırakılır. Ürün dizme yapılmaz.

The products are dropped down through the mould. The product is not stacked.

Model	I.M.M TON	Crosswise (X-axis)		Vertical (Y-axis)		Traverse		Max.power consumption	Max.payload	Controller	Power Source	Driving Method
		Stroke	Speed	Stroke	Speed	Stroke	Speed					
ATAK	350-650	1200	2m/sn	1200	Telescopic: 3m/sn Non Telescopic: 1.5m/sn	2250	1.5m/sn	3,25 KW	10 - 20 kg	Siemens Mobil Panel	AC 380 V, 50/60 Hz	(All axes) AC Servo